

# ASSEMBLY INSTRUCTION

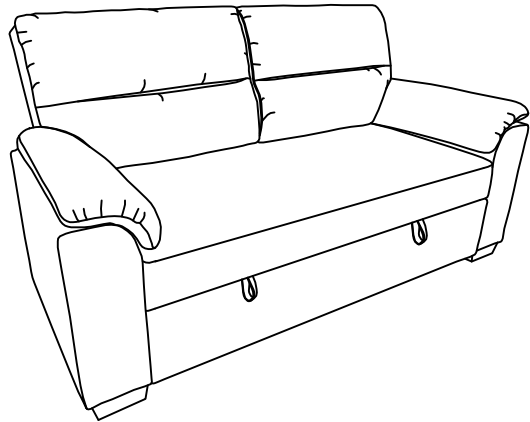

## PARTS AND HARDWARE

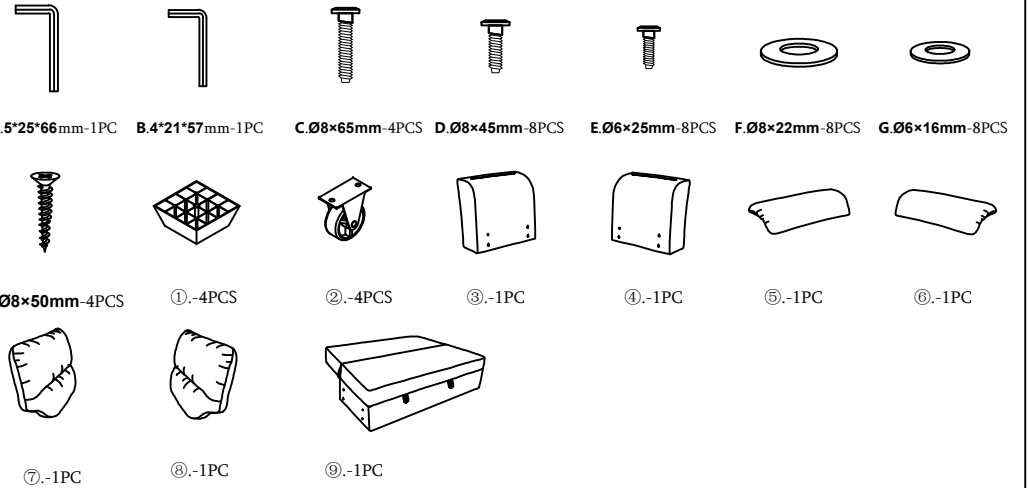

## ASSEMBLY INSTRUCTIONS

Step 1

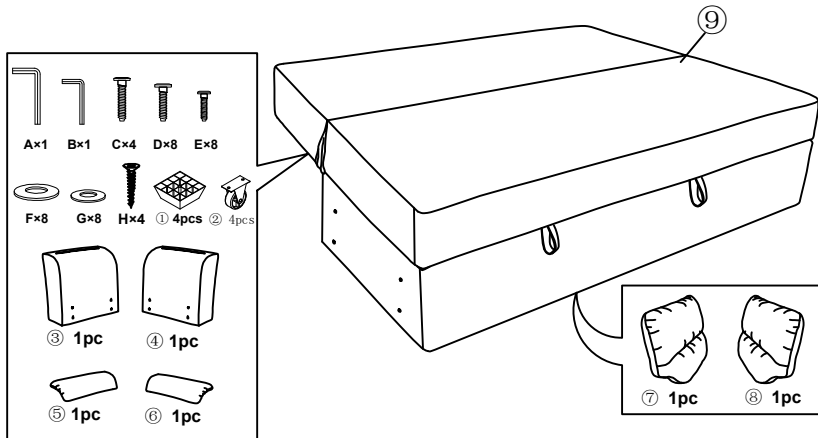

Step 2

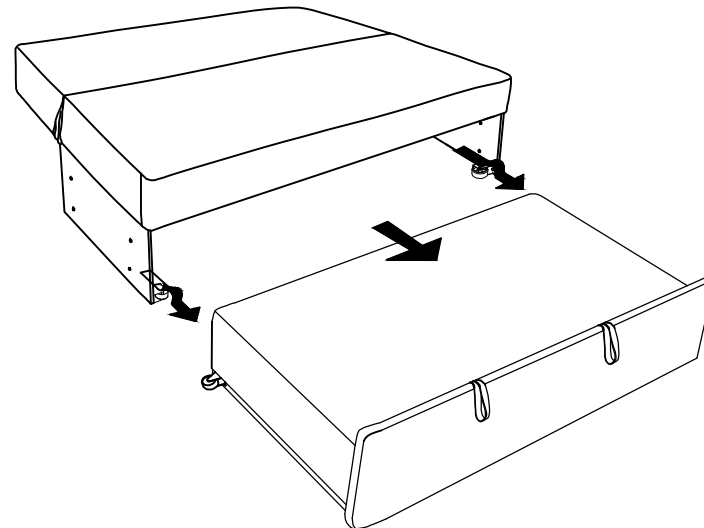

# OPERATING YOUR UNIT

## Step 3

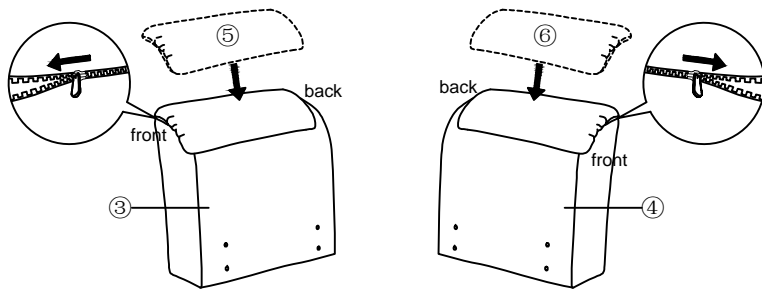

## Step 4

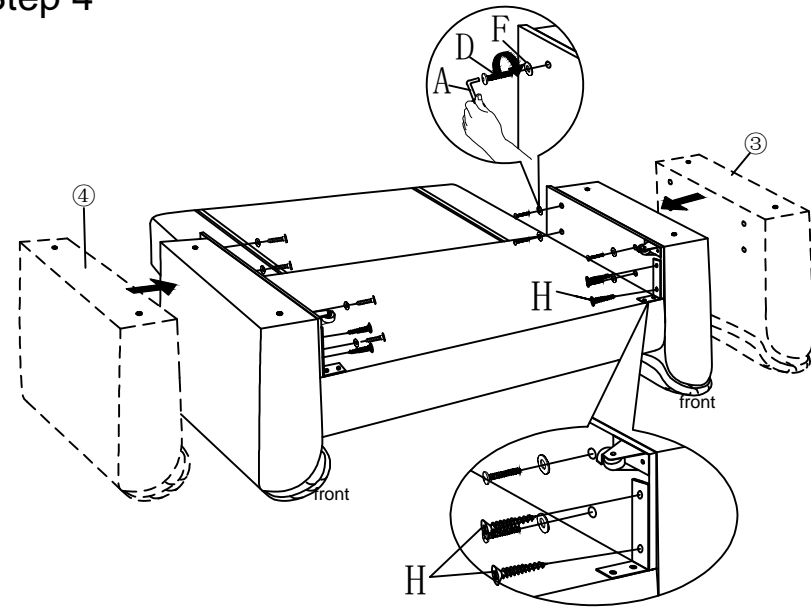

## Step 5

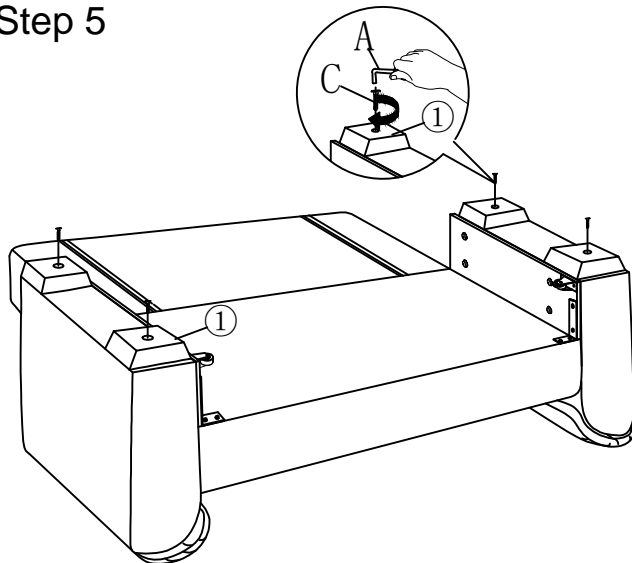

## Step 6

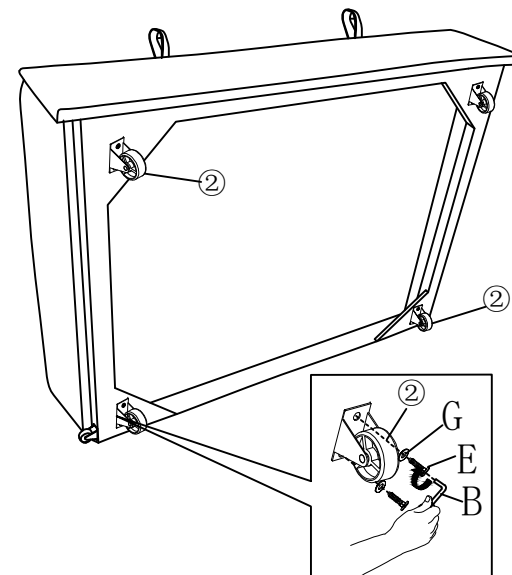

# OPERATING YOUR UNIT

Step 7

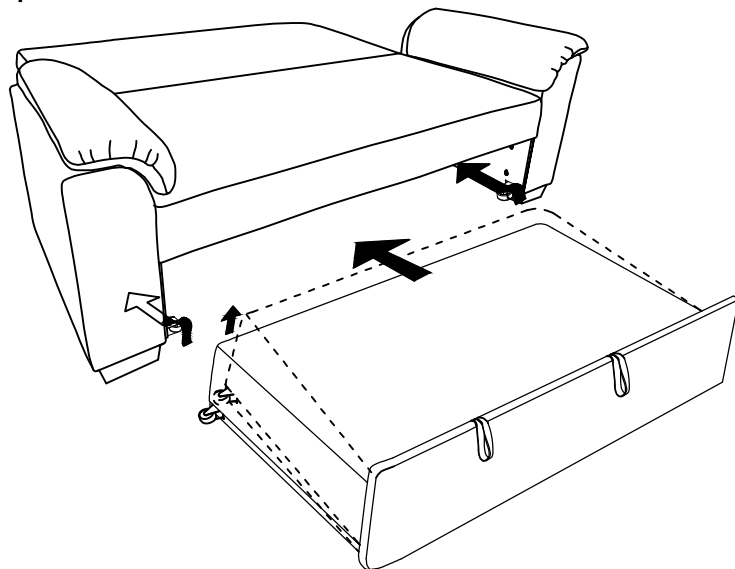

Step 8

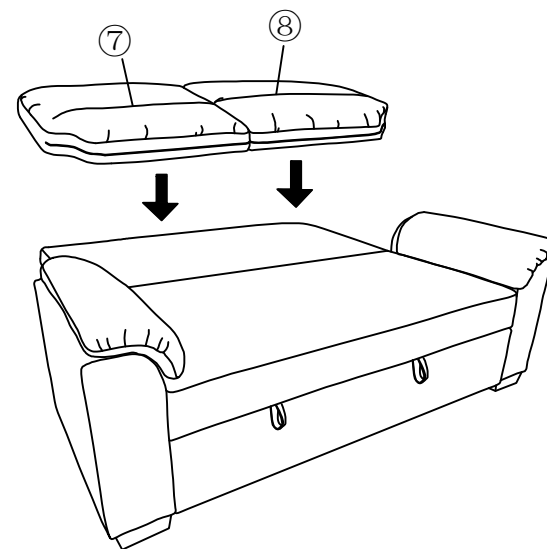

Step 9

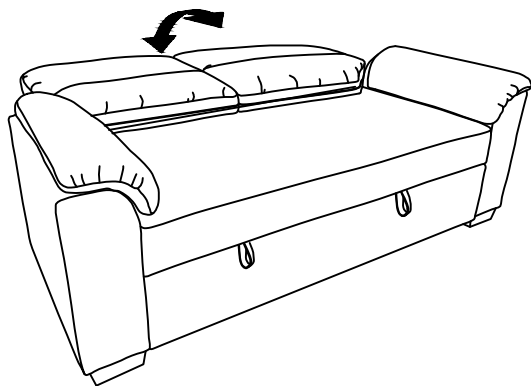

Step 10

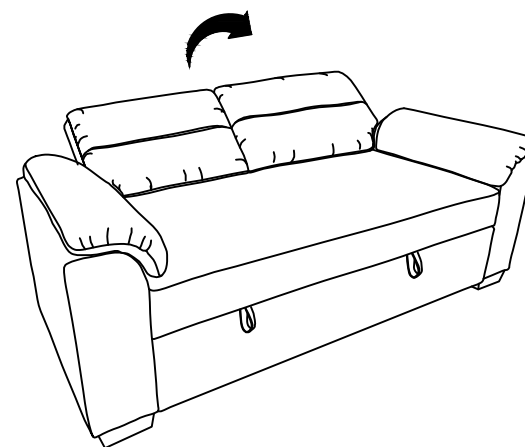

# OPERATING YOUR UNIT

Step 11

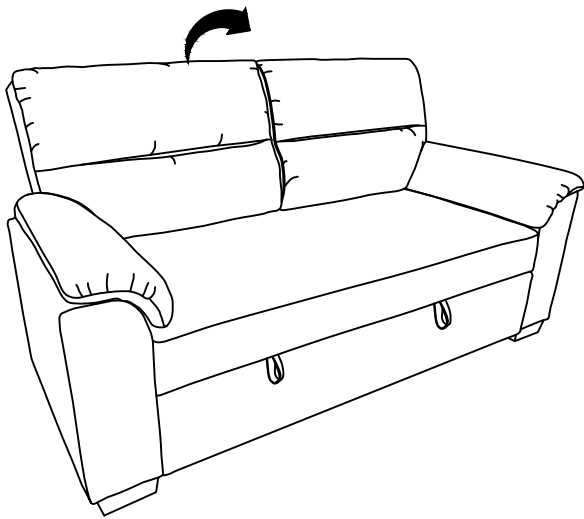

Step 12

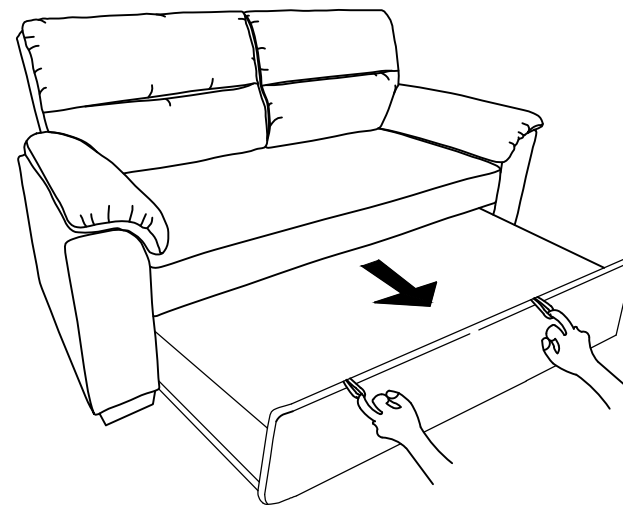

Step 13

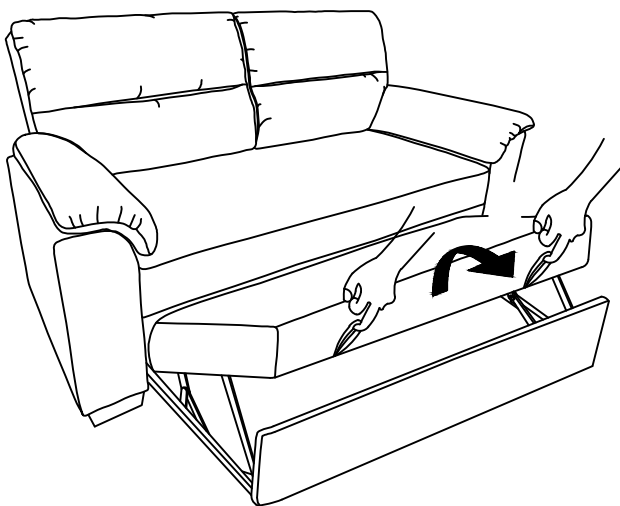

Step 14

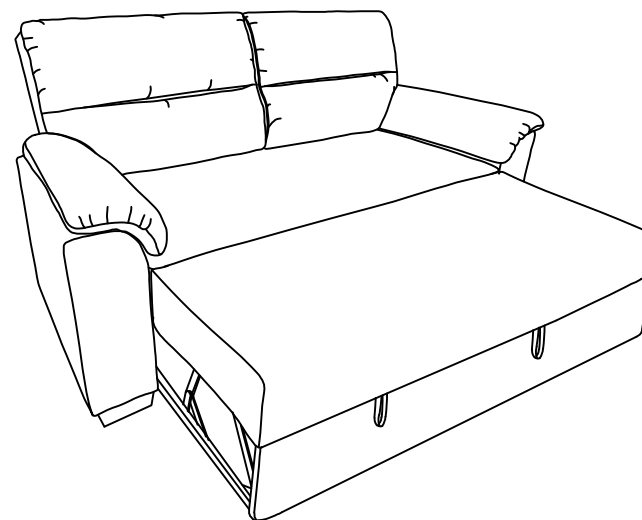

# OPERATING YOUR UNIT

Step 15

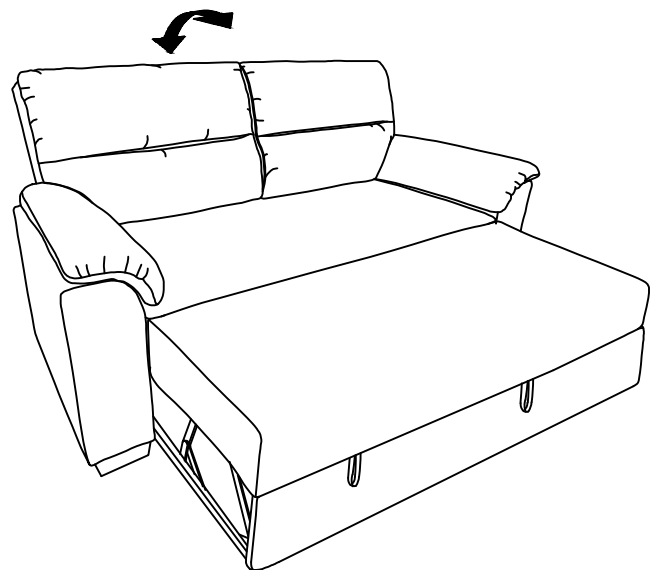

Step 16

